

Manual Catalog

Parts List	01-03	Head Set	10
Tools List	04	Front Fork	11
Handlebars	05	Head Tube Spacer	12
Seat Post	06	Brake Cable	13-14
Saddle Clamp	07	Electronic Derailleur Wiring	15-18
Front Derailleur Hanger &Front Barrel Shaft	08	Mechanical Derailleur Wiring	19-22
Rear Derailleur Hanger &Rear Barrel Shaft	09		





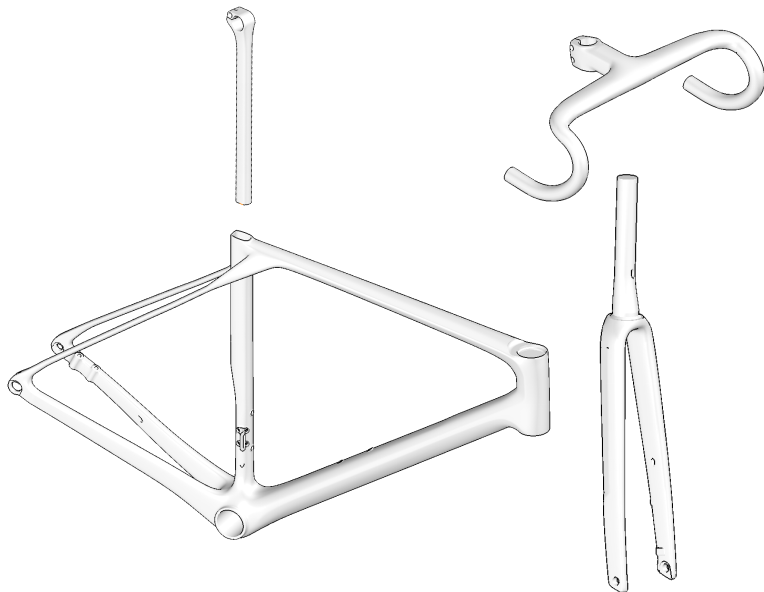

Attention







This manual is designed to only assist ELILEE retailers in completing the assembly of the BLIZE01 model bicycle. The assembly of this bicycle requires professional knowledge and specific tools, and only the components specified by ELILEE are installed. If the instructions provided in this manual are not followed, resulting in incorrect and unsafe assembly of the bicycle, the bicycle will lose control and cause serious injury to the rider.

Parts List











Parts List

NO.	Thumbnail	Name	Identifier	Quantity
1		brake cable crossing base	R-001	1
2		electric cable crossing base	R-002	1
3		rear derailleurs hanger	R-003	1
4		rear derailleurs cable crossing base	R-004	1
5		barrel shaft	R-005	2
6		saddle clamp-A	R-006	1

NO.	Thumbnail	Name	Identifier	Quantity
7		saddle clamp-B	R-007	1
8		saddle clamp-B2	R-008	1
9		saddle clamp-C	R-009	1
10		seat post lock	R-010	1
11		anti slip plate	R-011	1
12		M6 Ti screw	R-012	2









Parts List









NO.	Thumbnail	Name	Identifier	Quantity
13		saddle clamp nut	R-013	1
14		M6 Ti saddle clamp screw	R-014	1
15		head set bearing	R-015	2
16		computer holder	R-016	1
17		stem cover	R-017	1
18		expander plug	R-018	1

NO.	Thumbnail	Name	Identifier	Quantity
19		head tube spacer A-1	R-019	5
20		head tube spacer A-2	R-020	5
21		head set cover (upper)	R-021	1
22		head set cover (under)	R-022	1
23		pressure ring	R-023	1

Tool List

This manual describes the assembly procedure for BLIZE bicycles. List most of the tools and components required in these processes. ELILEE strongly recommends that all assembly and adjustment procedures be conducted by ELILEE authorized retailers.

	bicycle workbench(stand)
	torque wrench with a range of 2.5Nm to 15Nm
	allen key: 2mm, 2.5mm, 3mm, 4mm, 5mm, 6mm, 8mm, 10mm
	wrench: 7mm, 8mm, 10mm, 17mm
	cable clamp
	needle nose pliers
	cross screwdriver
	slotted screwdriver

	pedal wrench
	bottom bracket wrench
	tire pump
	alcohol
	Di2 cable tool
	bicycle grease and carbon fiber assembly anti slip agent
	fixed seat for cutting pipe
	saw for steel&saw for carbon

Handlebars Installation

The handlebars in this frame set are integrated handlebars, and the installation and placement of the computer holder are shown in the figure. After placing the computer holder in the position shown in the figure, use M5 screws to fix it.

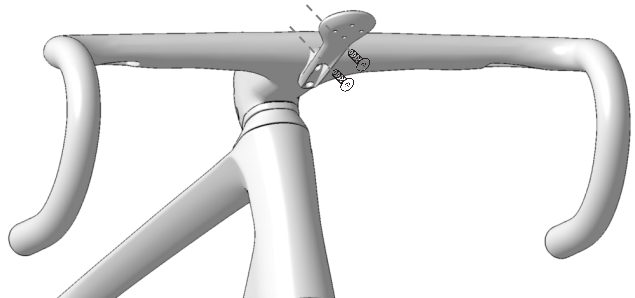
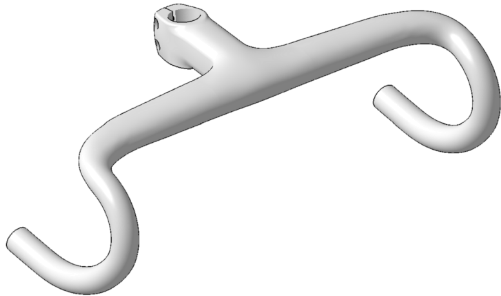
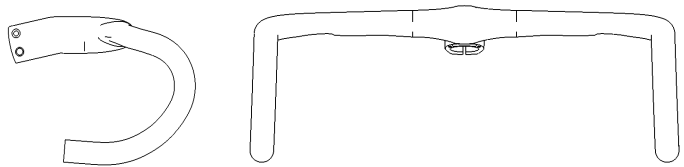

Seat Post Installation

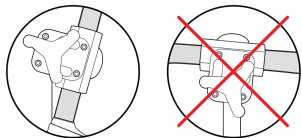

Attention: It is best to clamp the seat post to fix the frame, as clamping the upper tube may damage the frame and invalidate the warranty.

The installation process of the frame seat post for this model:

1. First, clip the seat post at the position shown in the diagram;
2. Apply carbon fiber anti slip agent evenly to the inner wall of the frame seat post installation tube and the surface of the seat post;
3. After adjusting the seat post to the appropriate height, screw in the M6 screw according to the hole position shown in the figure, and the torque of the seat post lock is 4-8N·m, depends on the weight of the rider (over 100kg max 8N·m).
4. If the length of the seat post needs to be modified, ensure that there is at least 70mm of seat post allowance left in the frame.

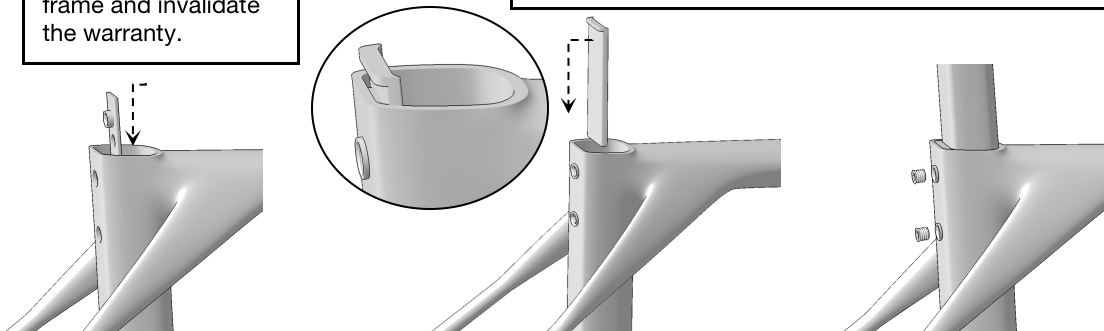

Saddle Clamp Installation

There are two models of saddle clamp come with the frame set.

(7mm*7mm/7mm*9mm)

- 1、 Place the saddle clamp on the converter.
- 2、 Place it at the installation point of the seat post shown in the figure.
- 3、 Insert the saddle clamp nut into the hole at the position shown in the figure.
- 4、 Insert the saddle clamp screw into the saddle clamp nut, Tighten according to the position shown in the diagram. Max torque is 8Nm.

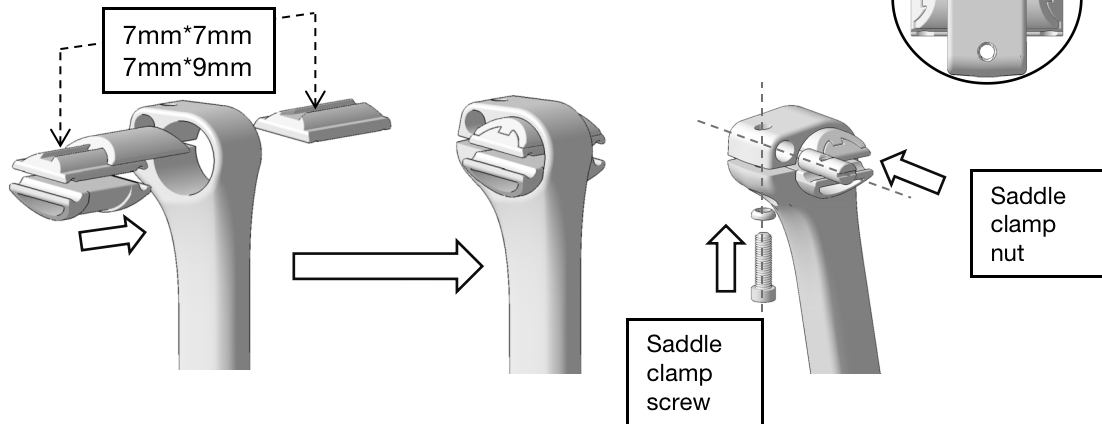

Front Derailleur Hanger&Front Barrel Shaft Installation

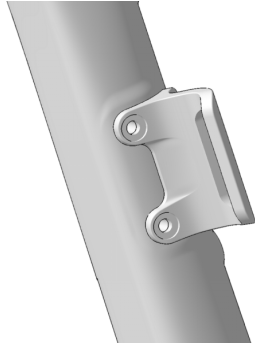

The front derailleur hanger is directly riveted to the frame, and the factory configuration is shown in the figure.

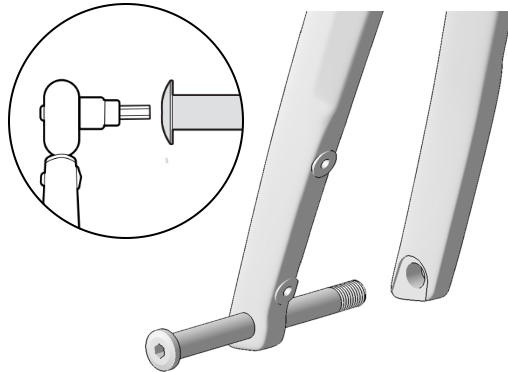

Insert the front barrel shaft according to the position shown in the diagram, and then tighten it with a torque wrench, with a maximum torque of 10Nm.

Rear Derailleur Hanger&Rear Barrel Shaft Installation

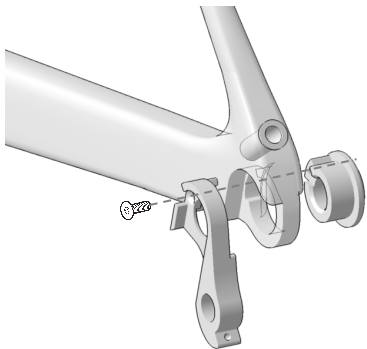

Place the hanger at the position shown in the figure, then tighten the M2.5 bolt.

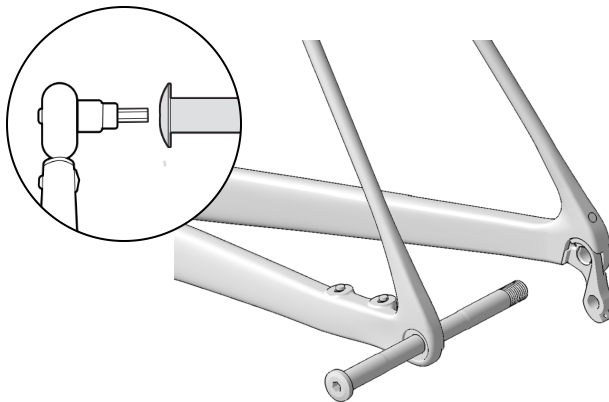

Insert the shaft at the position shown in the figure, then use torque wrench to tighten it.
Max torque is 10Nm.

Head Set Installation

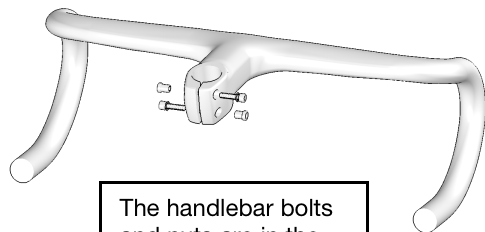
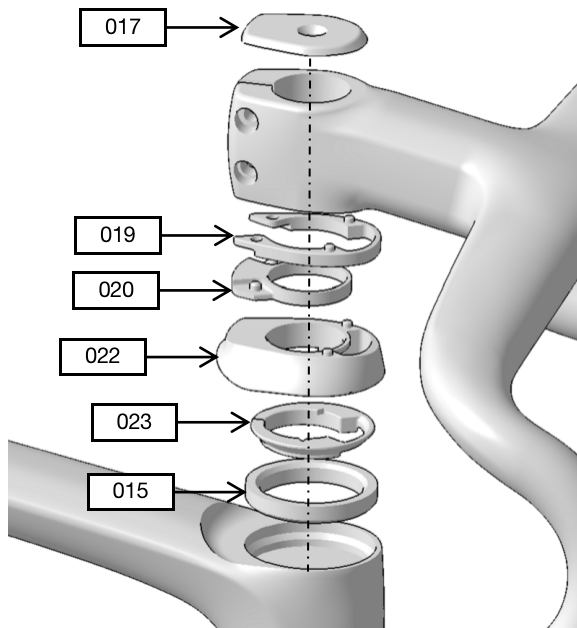

The handlebar bolts and nuts are in the form of a lock, as shown in the figure, with a torque of 5Nm.

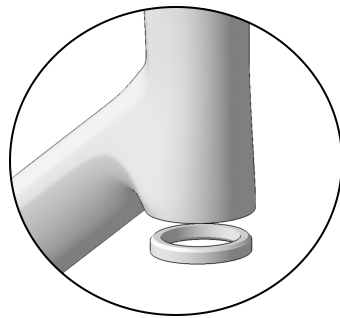

Front Fork Installation

1. Apply grease to the inner and outer mounting surfaces of the head bearing first, and then install the upper and lower head bearing into the frame; 2. Place the spacer, handlebars, and head set cover provided by the frame together on the frame, and adjust the height of the handlebars; 3. After slightly pressuring them and making sure they are in a right place, mark the front fork at the surface shown in the figure; 4. Make another mark 4mm below the first mark, use a dedicated pipe cutting tool.

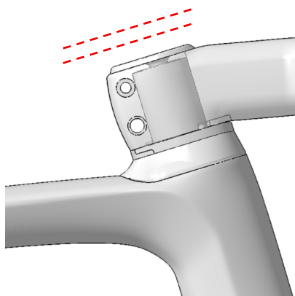
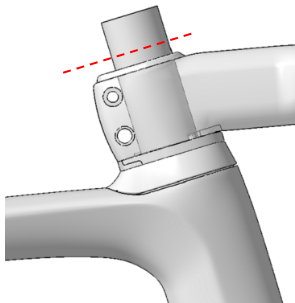

After confirming the length of the front fork steering column, wipe the inside of the front fork steering pipe wall with alcohol to avoid impurities or dust on the contact surface. After the front fork is dry, apply anti-slip agent to the expander plug and place it in the front fork. Ensure that the position is correct and the upper plane of the expander plug is parallel to the cutting surface, and then tighten the expander plug bolt with a maximum torque of 5-6Nm.

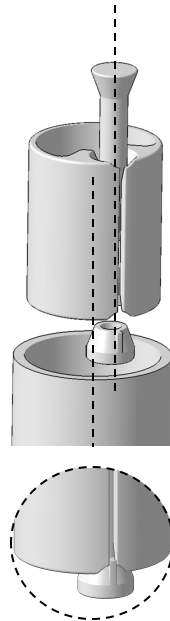

Head Tube Spacer Installation

If the height of the head tube requires additional padding, additional accessories (head tube spacers) can be used to pad under the handlebars, as shown in the figure.

The two-piece type spacer can be disassembled and assembled, as shown in the figure.

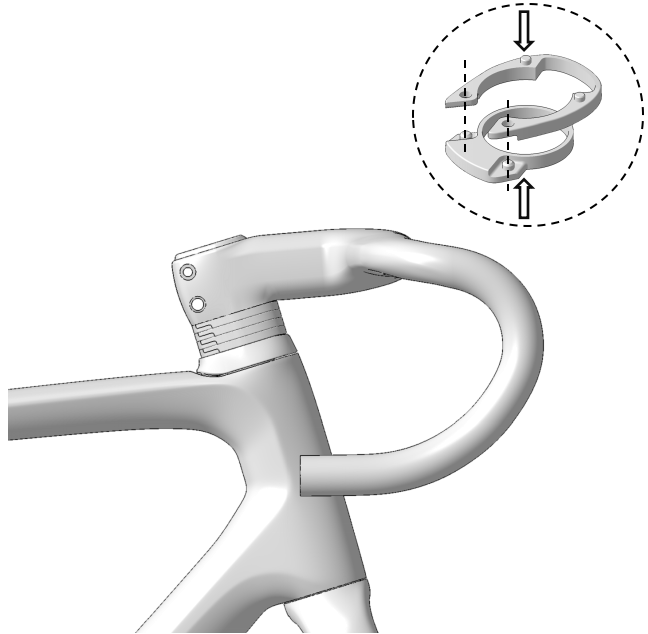

Brake Cable Wiring

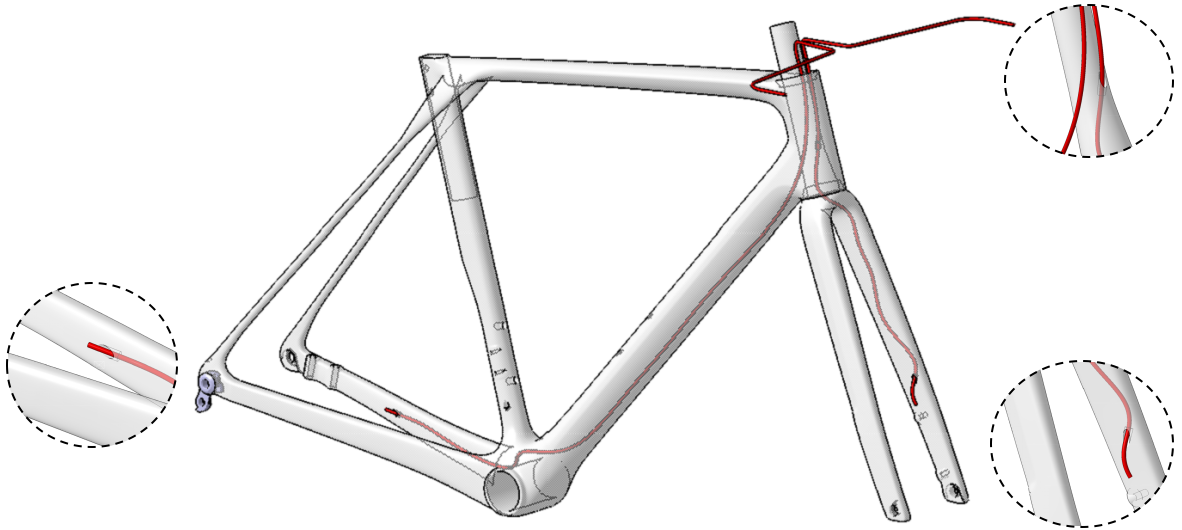

These wiring diagrams are only a supplement to the technician's installation instructions.

Brake Cable Wiring

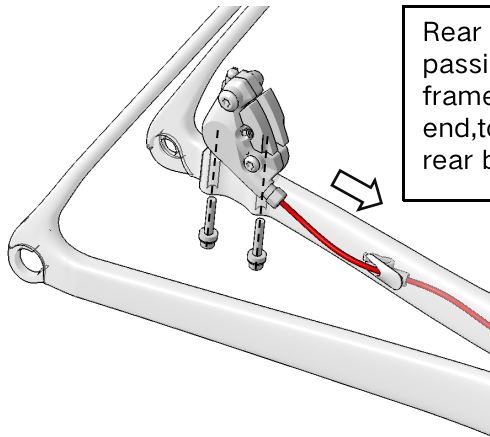

Rear brake cable passing through the frame and rear end, to connect the rear brake.

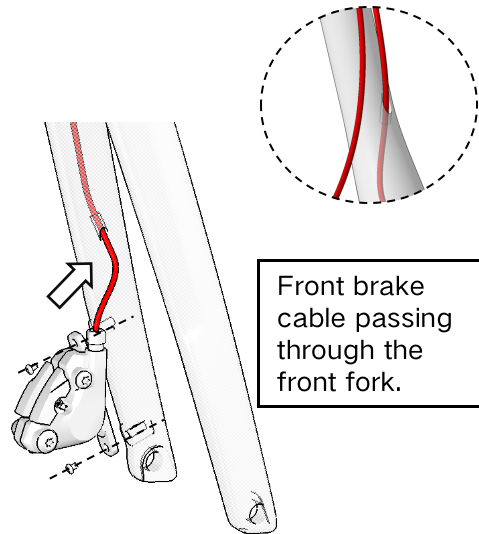

Front brake cable passing through the front fork.



Brake screw effective length is 25mm.

Electronic Derailleur Cable Wiring

- Brake cable wiring
- Derailleur cable wiring

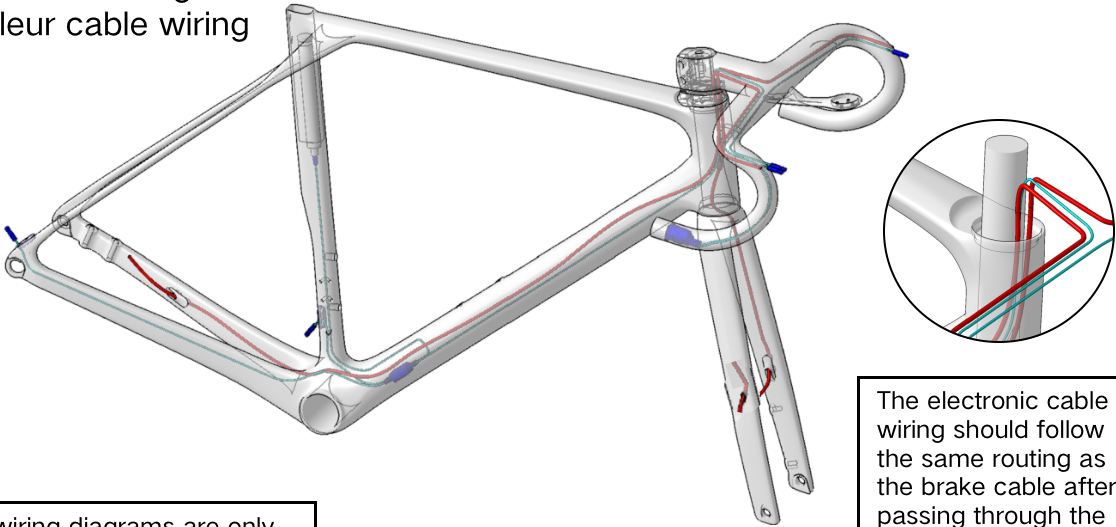

These wiring diagrams are only a supplement to the technician's installation instructions.

The electronic cable wiring should follow the same routing as the brake cable after passing through the head pipe.

Electronic Derailleur Cable Wiring

- Brake cable wiring
- Derailleur cable wiring

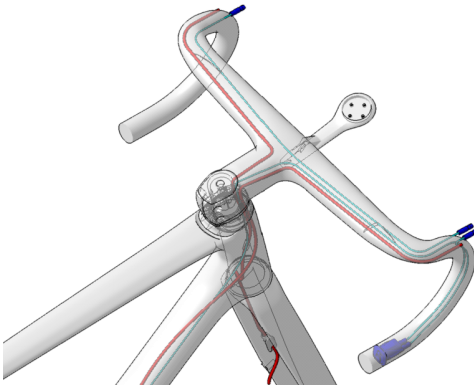

Place the electronic controller at the position shown in the figure.

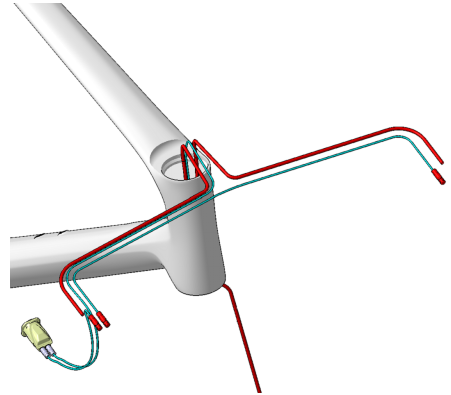

These wiring diagrams are only a supplement to the technician's installation instructions.

SHIMANO Di2 Wiring

- Brake cable wiring
- Derailleur cable wiring

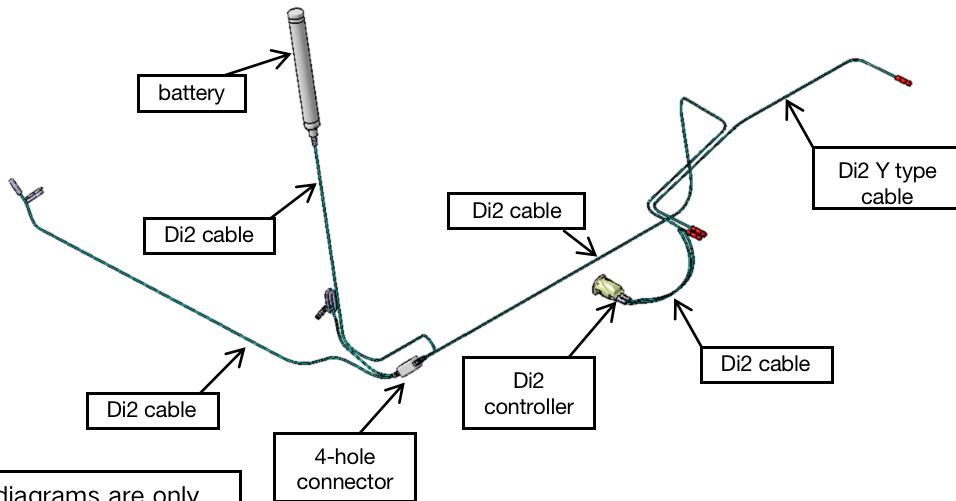

These wiring diagrams are only a supplement to the technician's installation instructions.

Electronic Derailleur Cable Wiring

Place the battery inside the seat post, fix it properly, insert the cable into the battery, then install the battery together with the seat post into the frame, as shown in the figure.

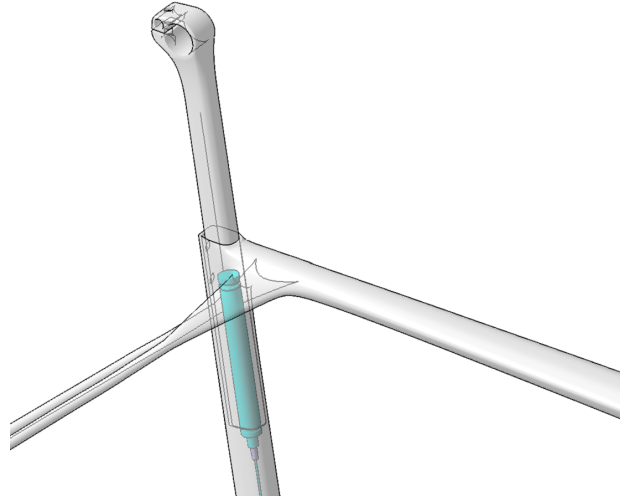
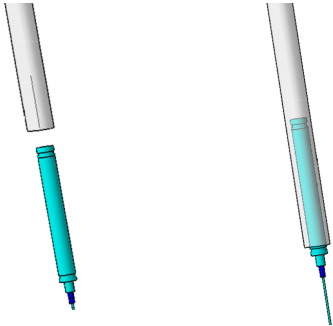

Mechanical Derailleur Cable Wiring(Internal)

- Brake cable wiring
- Derailleur cable wiring

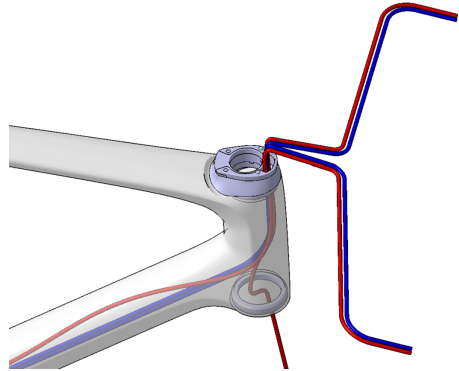
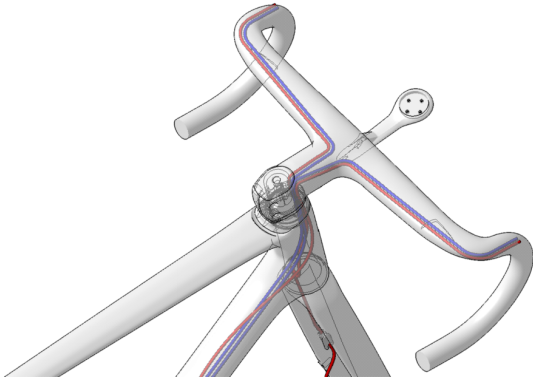

These wiring diagrams are only a supplement to the technician's installation instructions.

Mechanical Derailleur Cable Wiring(external)

- Brake cable wiring
- Derailleur cable wiring

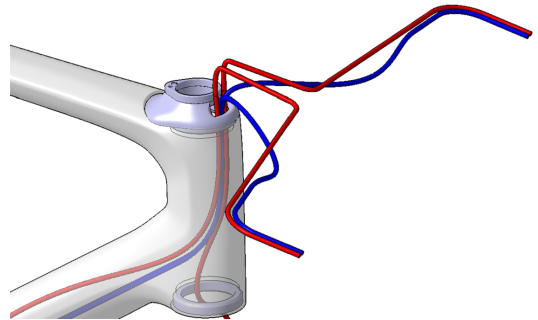
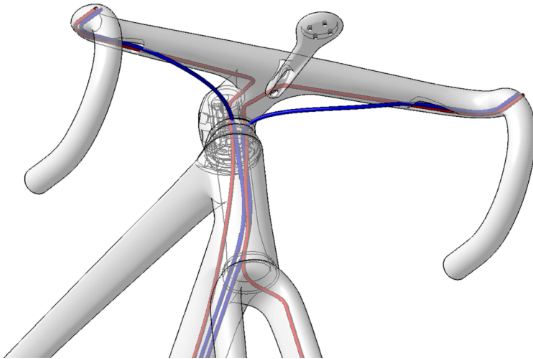

These wiring diagrams are only a supplement to the technician's installation instructions.

Mechanical Derailleur Cable Wiring

- Brake cable wiring
- Derailleur cable wiring

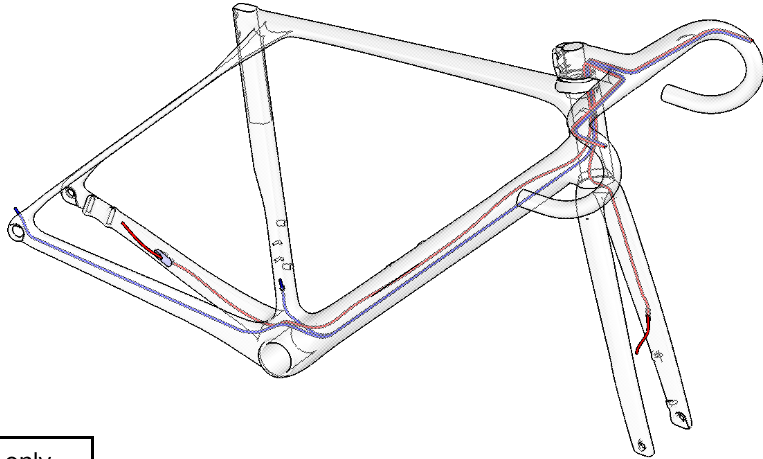

These wiring diagrams are only a supplement to the technician's installation instructions.

Mechanical Derailleur Cable Wiring

- Brake cable wiring
- Derailleur cable wiring

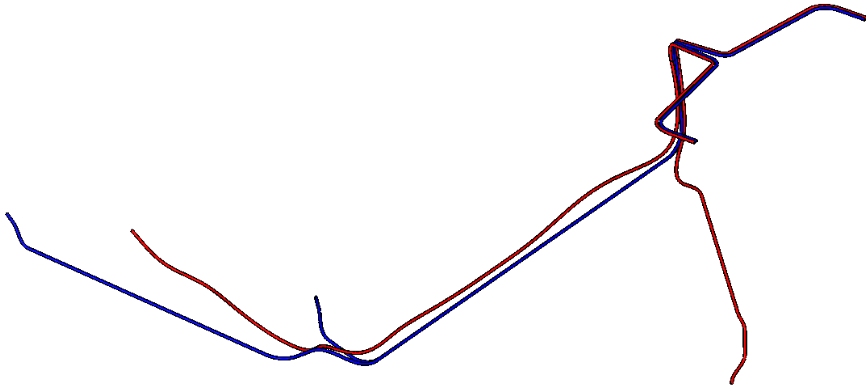

These wiring diagrams are only a supplement to the technician's installation instructions.